

PROJET N°: 3

COLONNE 160 CD

DESCRIPTIF :

Ce range-CD va vous permettre de classer jusqu'à 160 disques.

Son design est inspiré des égalizers numériques que l'on trouve aussi bien sur du matériel grand public que professionnel.

Bon bricolage.

PUBLIE LE : 21/12/2008

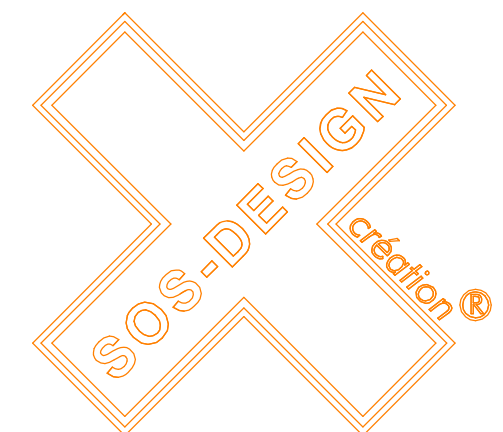

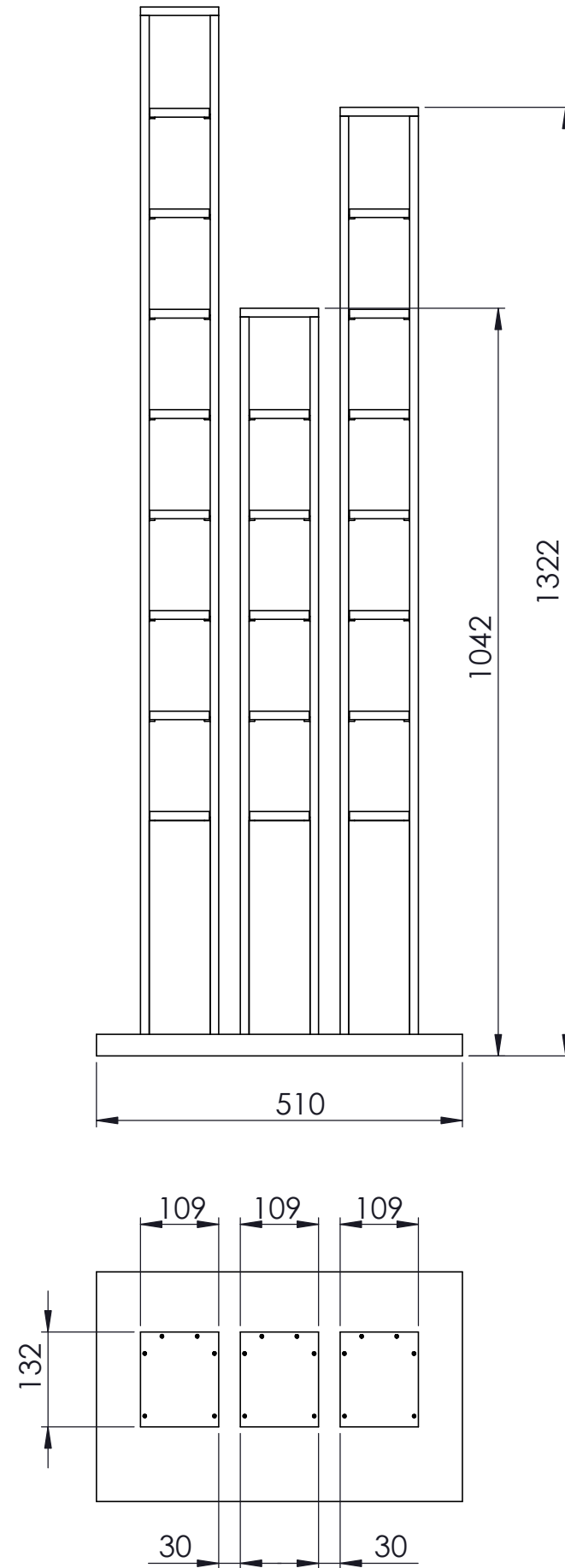
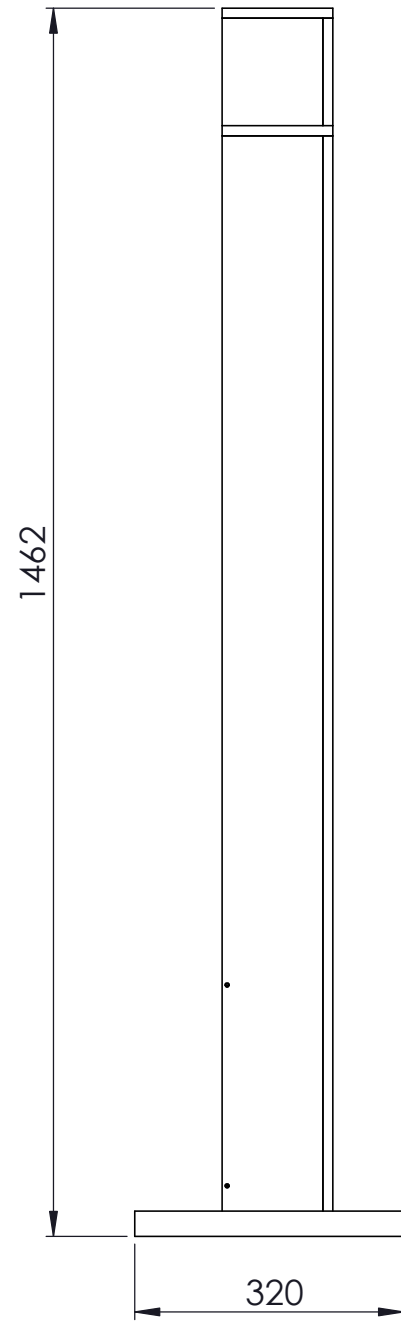

PROJET N°: 3

COLONNE 160 CD

DESCRIPTIF :

PUBLIE LE : 21/12/2008

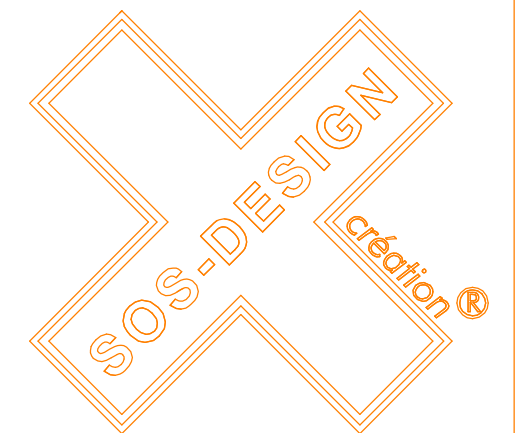

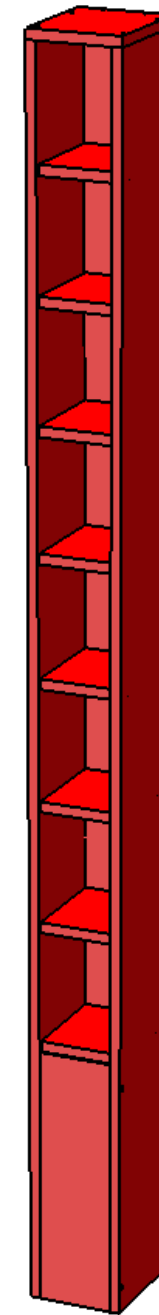
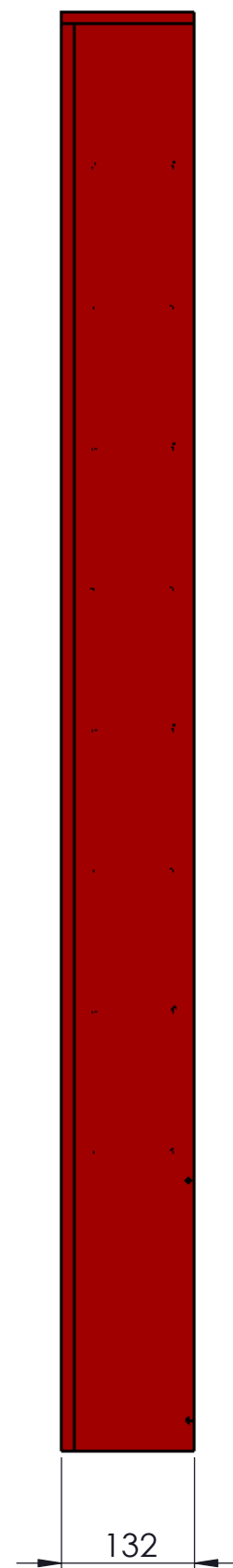
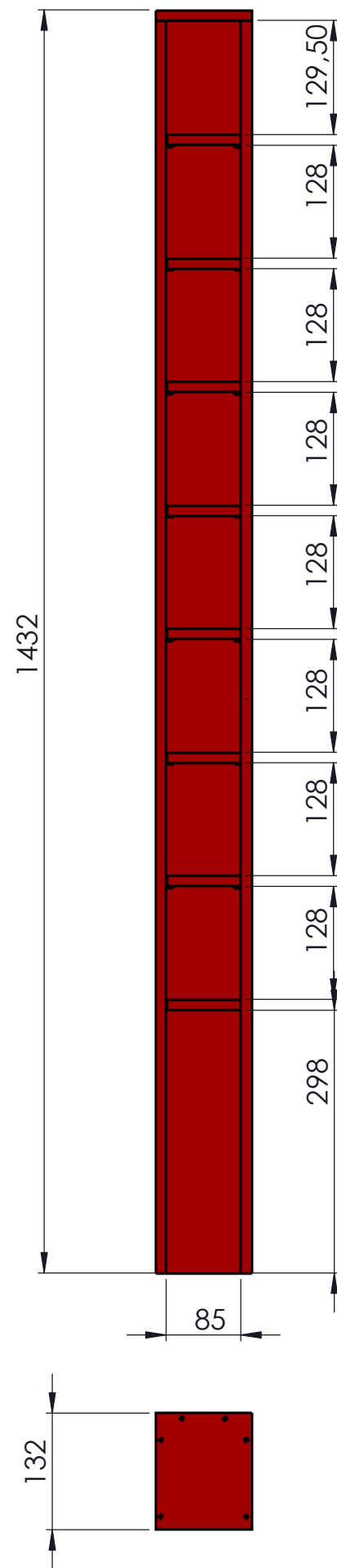

PROJET N°: 03

COLONNE 160 CD

DESCRIPTIF :

Cette première colonne peut contenir jusqu'à 64 CD.

PUBLIE LE : 21/12/2008

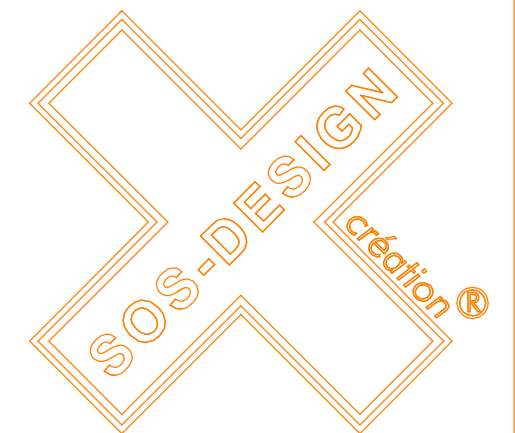

PROJET N°: 03

COLONNE 160 CD

DESCRIPTIF :

Nomenclature 1° colonne

PUBLIE LE : 21/12/2008

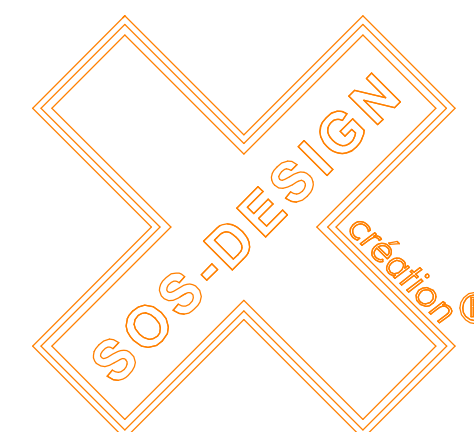

Ce plan a été créé et est offert par SOS-DESIGN. Vous êtes libre de l'adapter aux techniques de bricolage que vous maîtriser. SOS-DESIGN n'est pas responsable de sa bonne exécution.

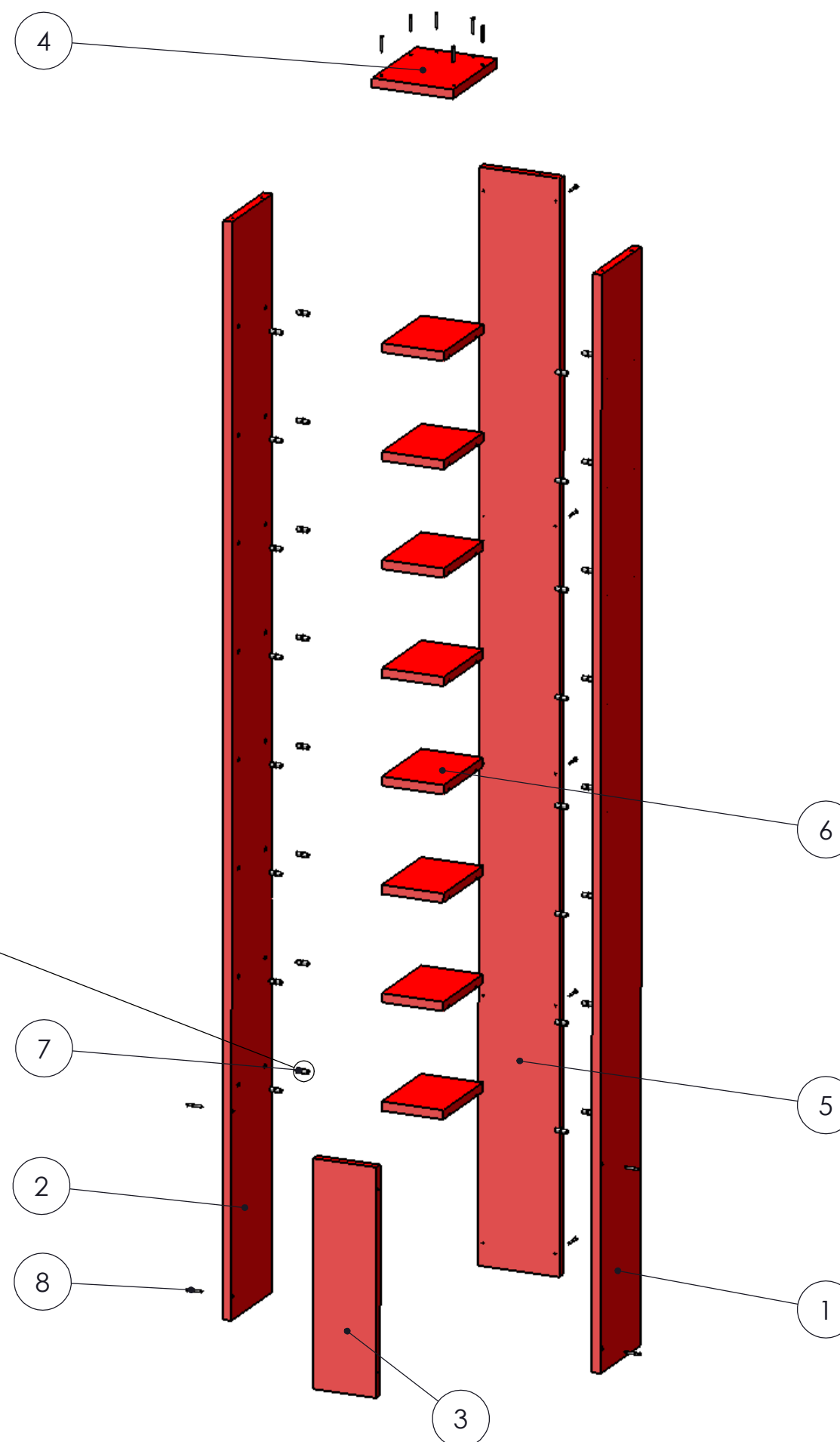
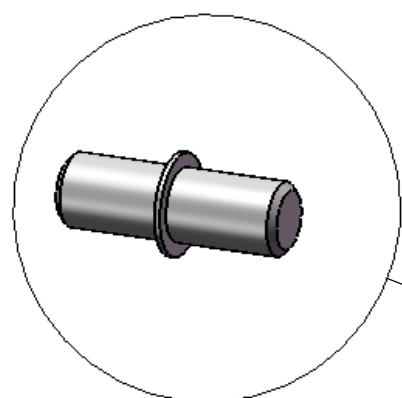

8	VIS	20
7	TAQUET A TENON	32
6	PLANCHE I	8
5	PLANCHE J	1
4	PLANCHE H	1
3	PLANCHE G	1
2	PLANCHE B	1
1	PLANCHE A	1
No. ARTICLE	NUMERO DE PIECE	QTE

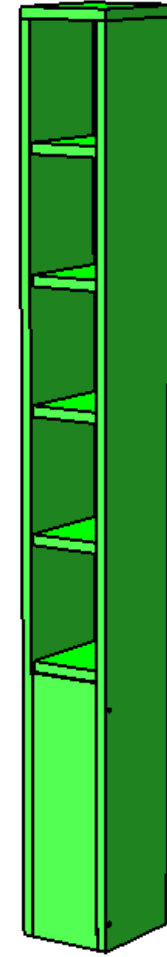
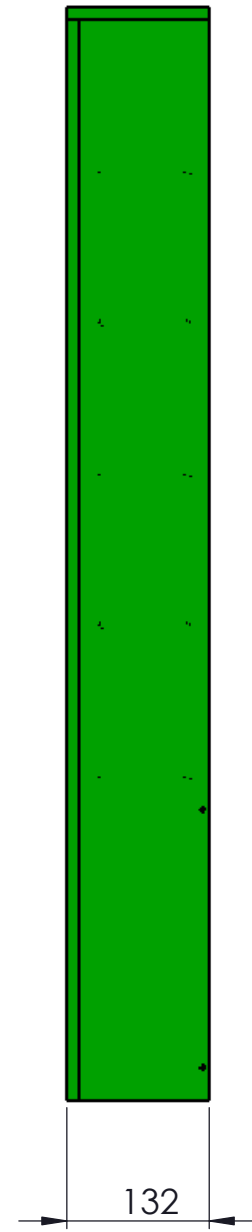
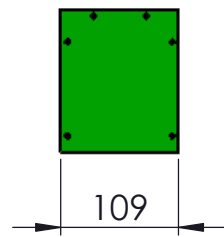
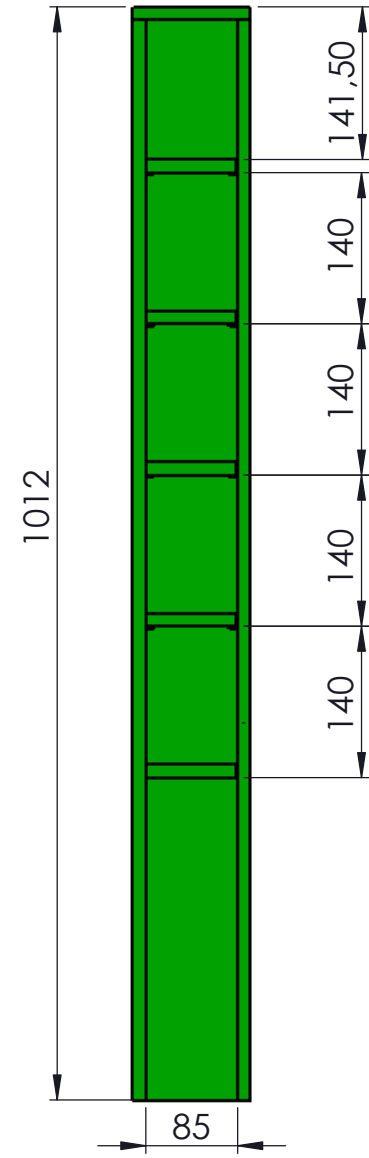

PROJET N°: 03

COLONNE 160 CD

DESCRIPTIF :

Cette seconde colonne peut contenir jusqu'à 40 CD.

PUBLIE LE :

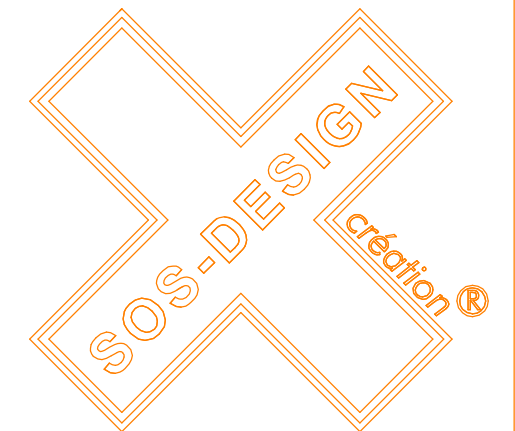

PROJET N°: 03

COLONNE 160 CD

DESRIPTIF :

Nomenclature 2° colonne

PUBLIE LE : 21/12/2008

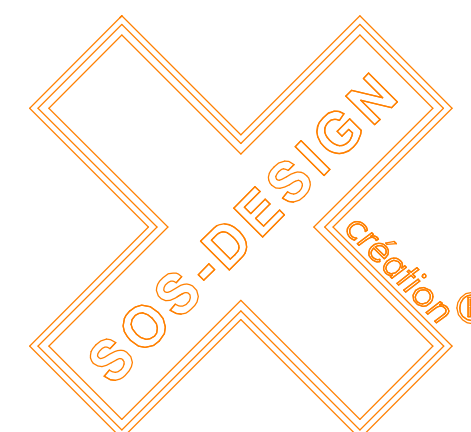

Ce plan a été créé et est offert par SOS-DESIGN. Vous êtes libre de l'adapter aux techniques de bricolage que vous maîtriser. SOS-DESIGN n'est pas responsable de sa bonne exécution.

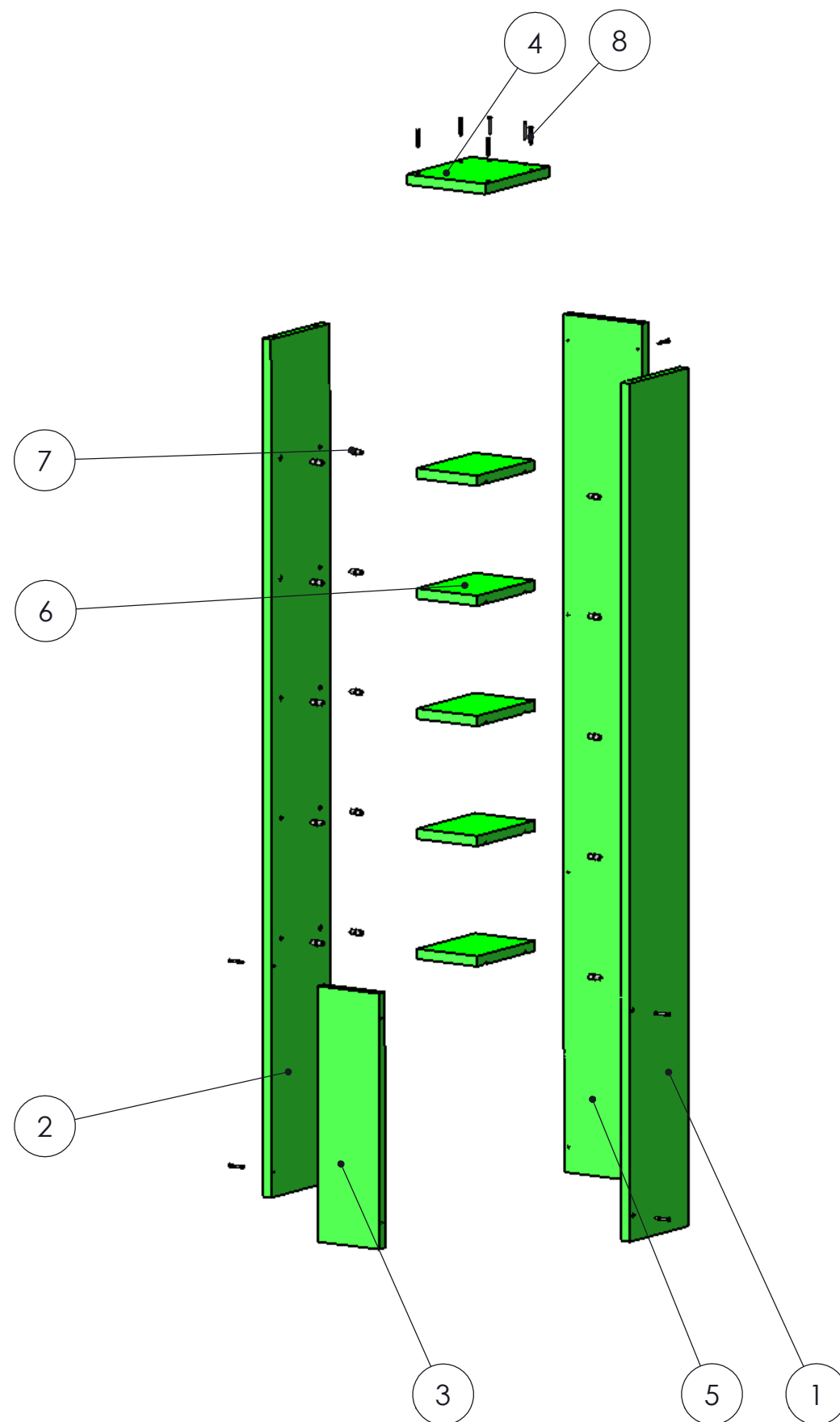

8	VIS	18
7	TAQUET A TENON	20
6	PLANCHE I	5
5	PLANCHE K	1
4	PLANCHE H	1
3	PLANCHE G	1
2	PLANCHE D	1
1	PLANCHE C	1
No. ARTICLE	NUMERO DE PIECE	QTE

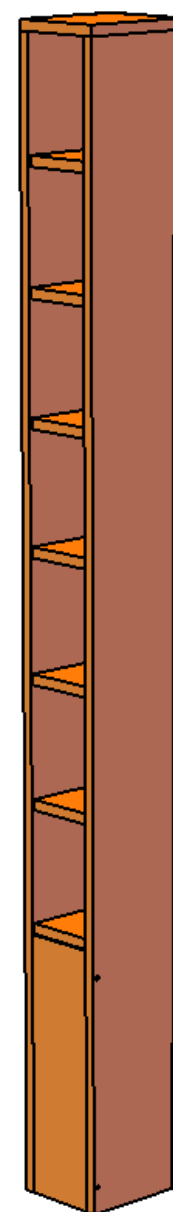
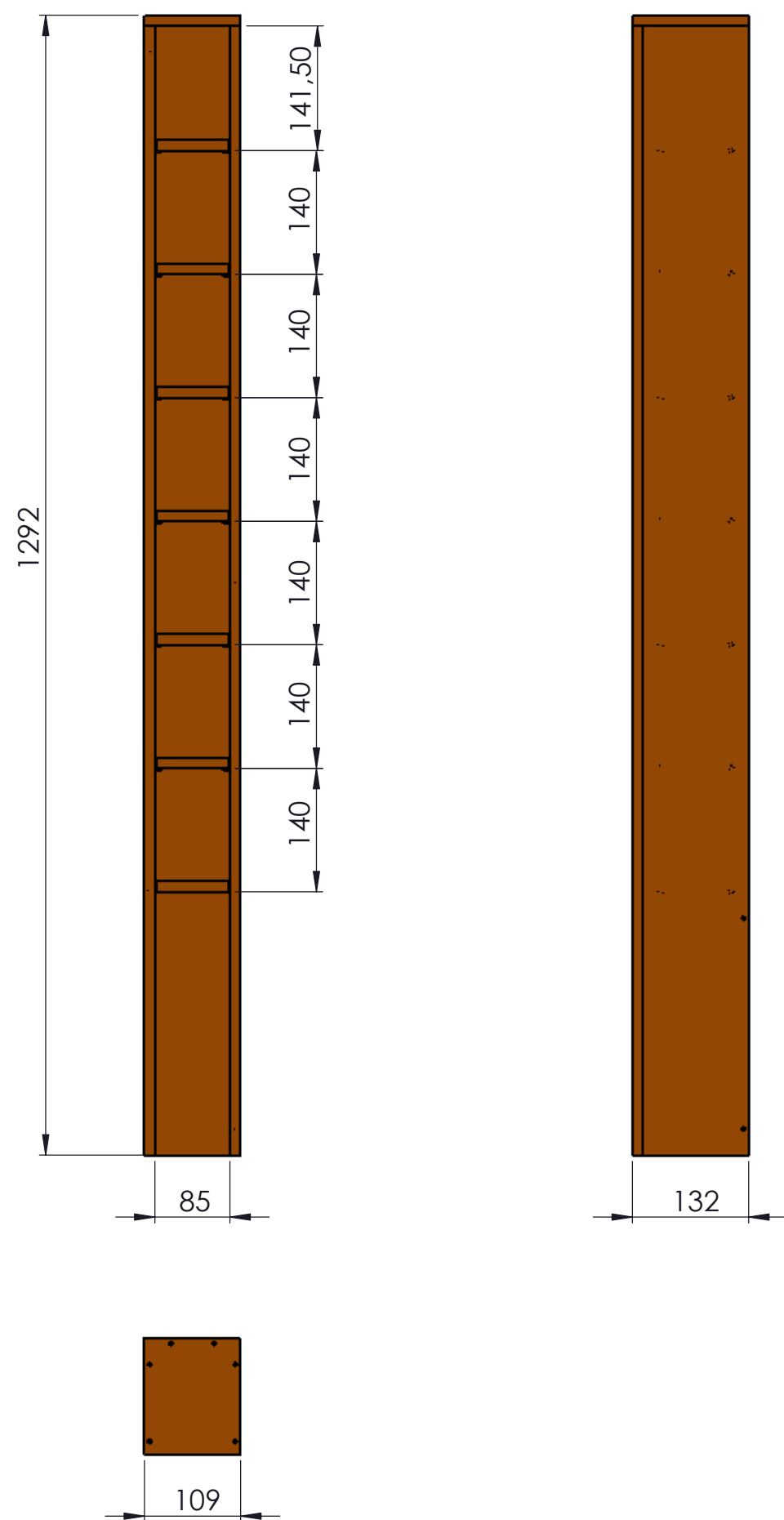

PROJET N°: 3

COLONNE 160 CD

DESCRIPTIF :

Cette troisième colonne peut contenir jusqu'à 56 CD.

PUBLIE LE : 21/12/2008

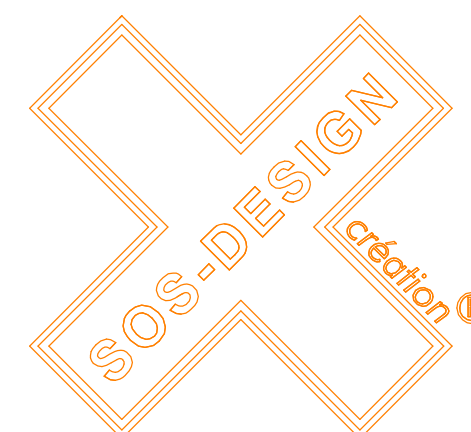

PROJET N°: 3

COLONNE 160 CD

DESCRIPTIF :

Nomenclature 3° colonne.

PUBLIE LE : 21/12/2008

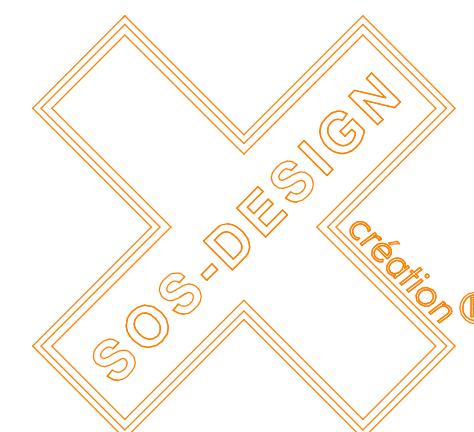

Ce plan a été créé et est offert par SOS-DESIGN. Vous êtes libre de l'adapter aux techniques de bricolage que vous maîtriser. SOS-DESIGN n'est pas responsable de sa bonne exécution.

8	VIS	18
7	TAQUET A TENON	28
6	PLANCHE I	7
5	PLANCHE L	1
4	PLANCHE H	1
3	PLANCHE G	1
2	PLANCHE E	1
1	PLANCHE F	1
No. ARTICLE	NUMERO DE PIECE	QTE

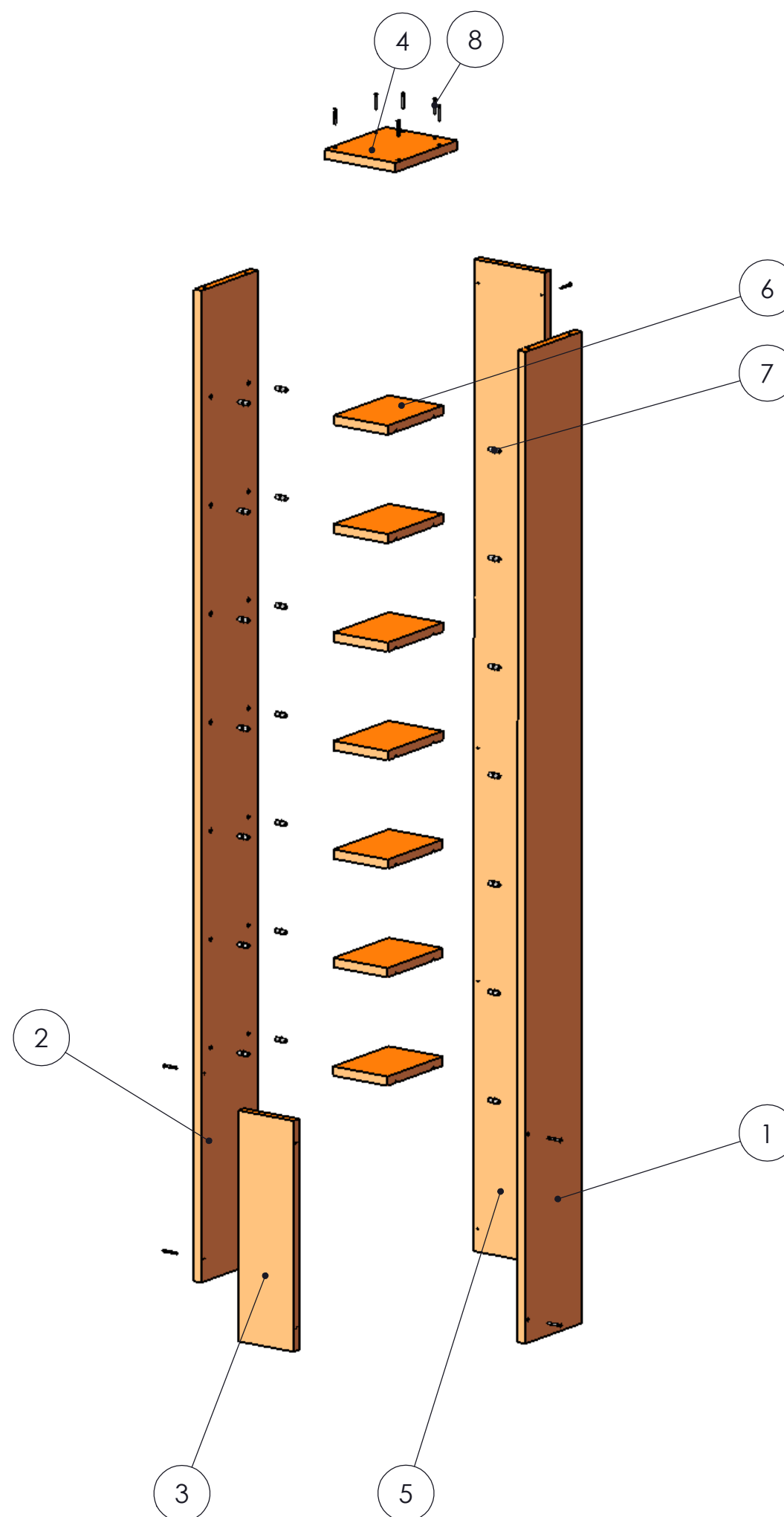

PROJET N°: 3

COLONNE 160 CD

DESCRIPTIF :

Assemblage des 3 colonnes sur le socle.

Vous pouvez placer des petits patins sous le socle.

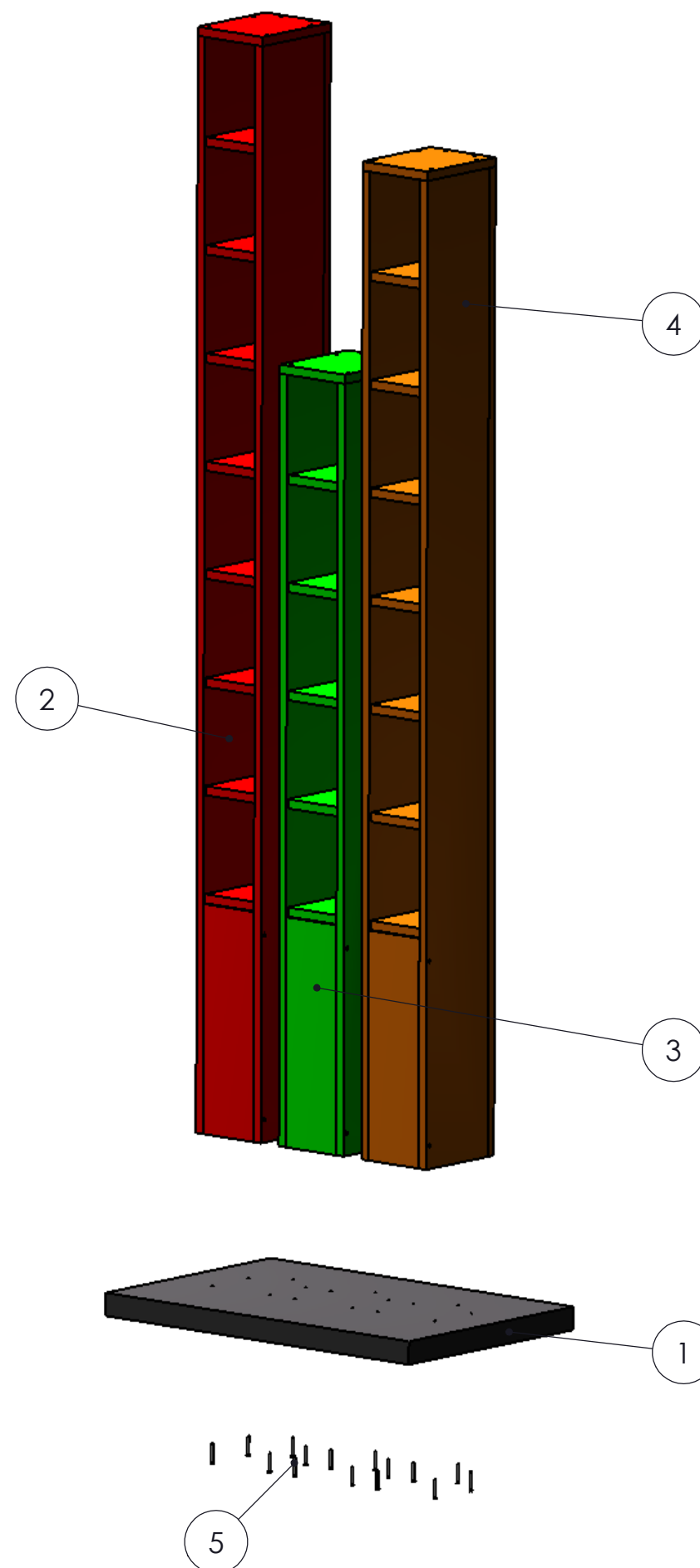

5	VIS	15
4	COLONNE 56 CD	1
3	COLONNE 40 CD	1
2	COLONNE 64 CD	1
1	PLANCHE M	1
No. ARTICLE	NUMERO DE PIECE	Quantité

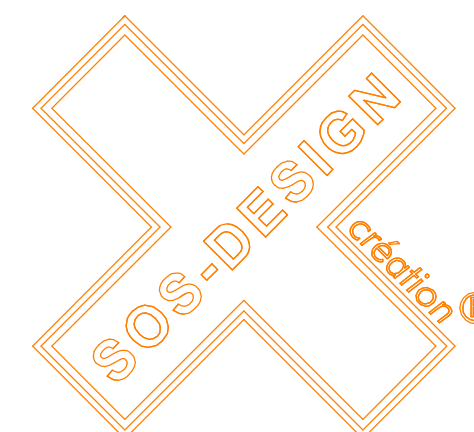
PUBLIE LE : 21/12/2008

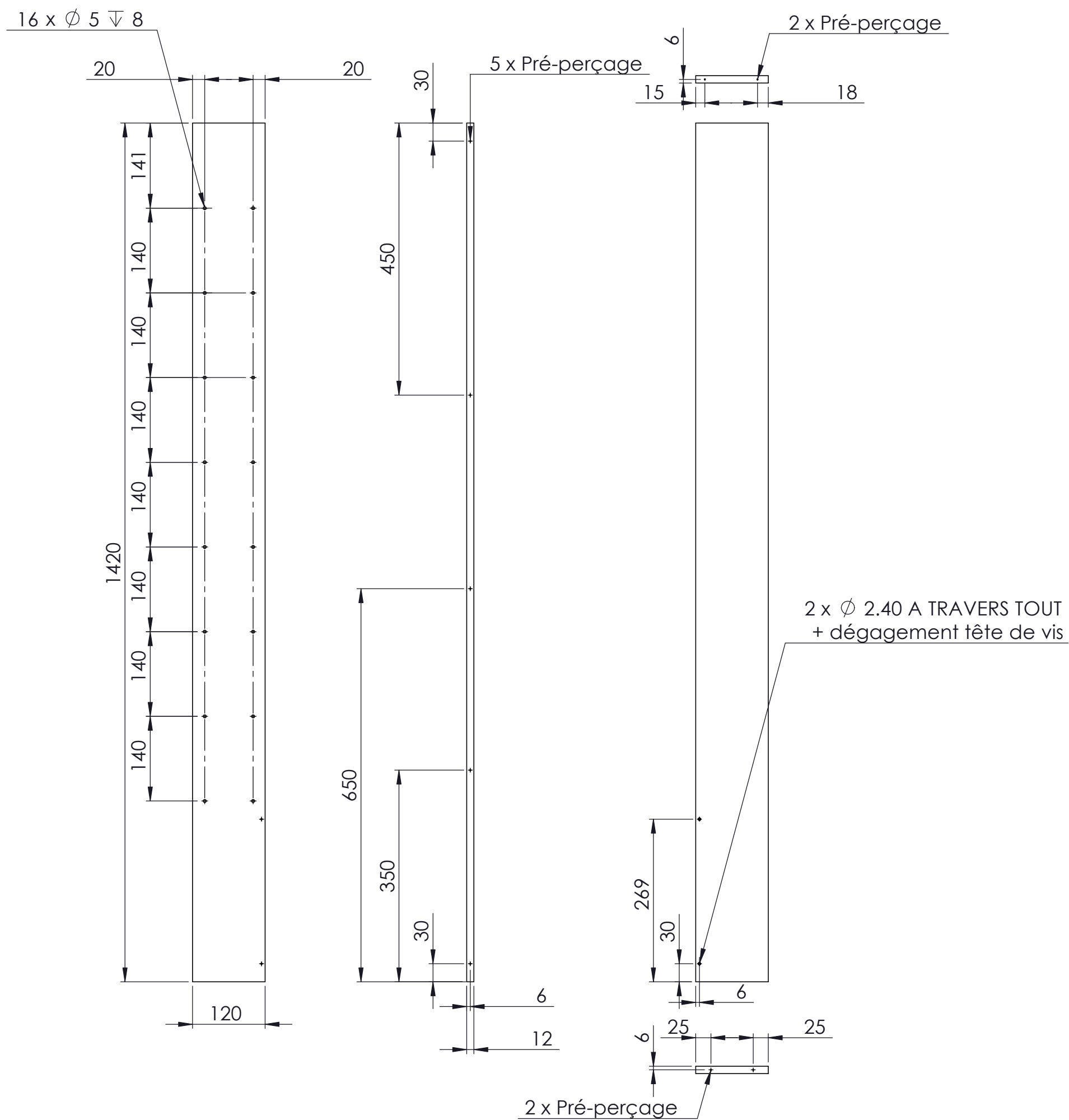

PROJET N°: 3

COLONNE 160 CD

DESRIPTIF :

PLANCHE A.

Sur cette page et les suivantes :
La flèche vers le bas signifie profondeur.

Le diamètre de pré-perçage doit correspondre au diamètre du corps de votre vis moins 1mm.

Choisissez des vis à tête fraisée afin de les rentrer totalement dans le bois. Ainsi, vous pourrez les recouvrir de pate à bois avant peinture.

PUBLIE LE : 21/12/2008

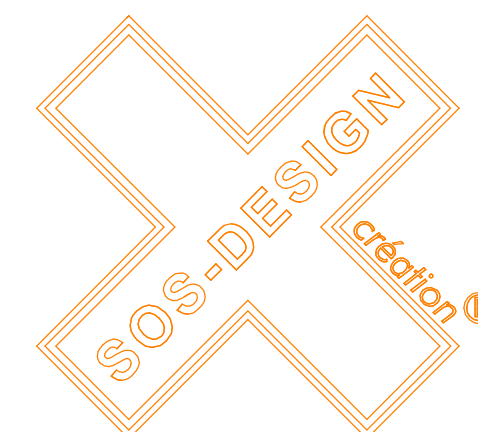

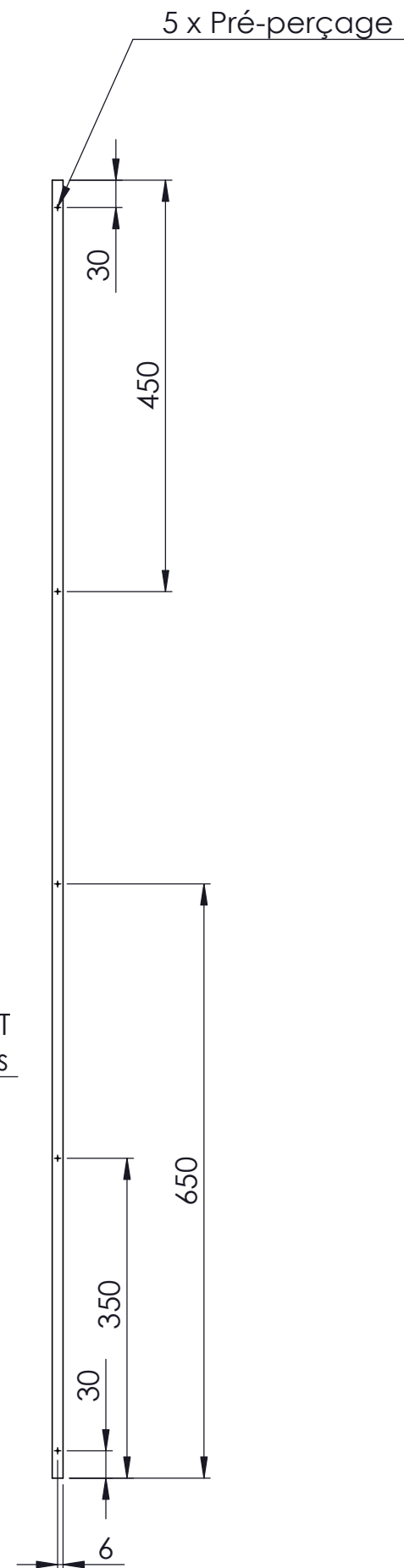
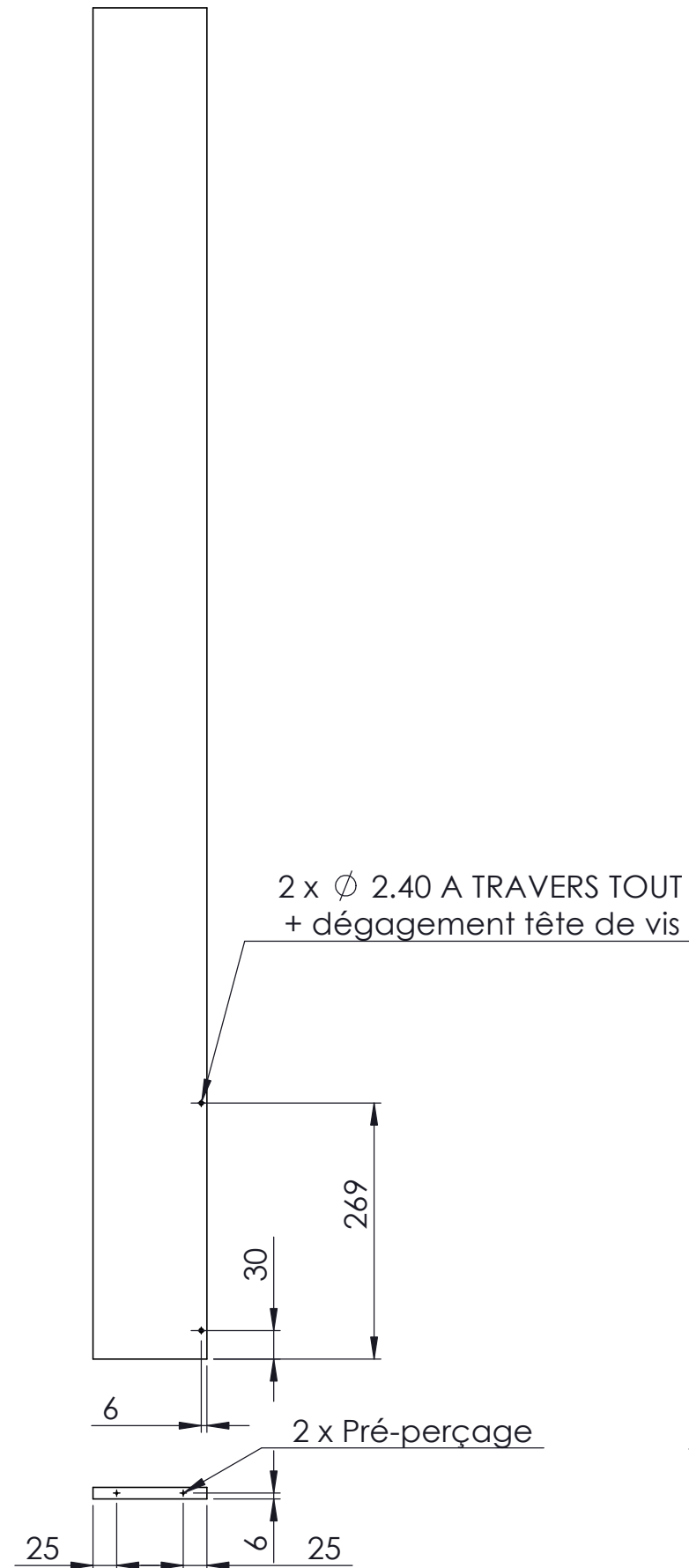
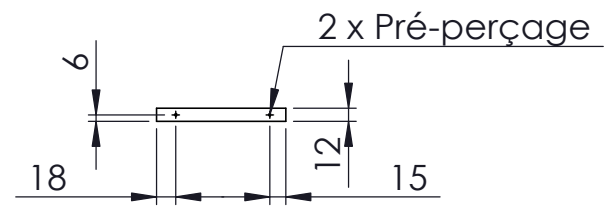
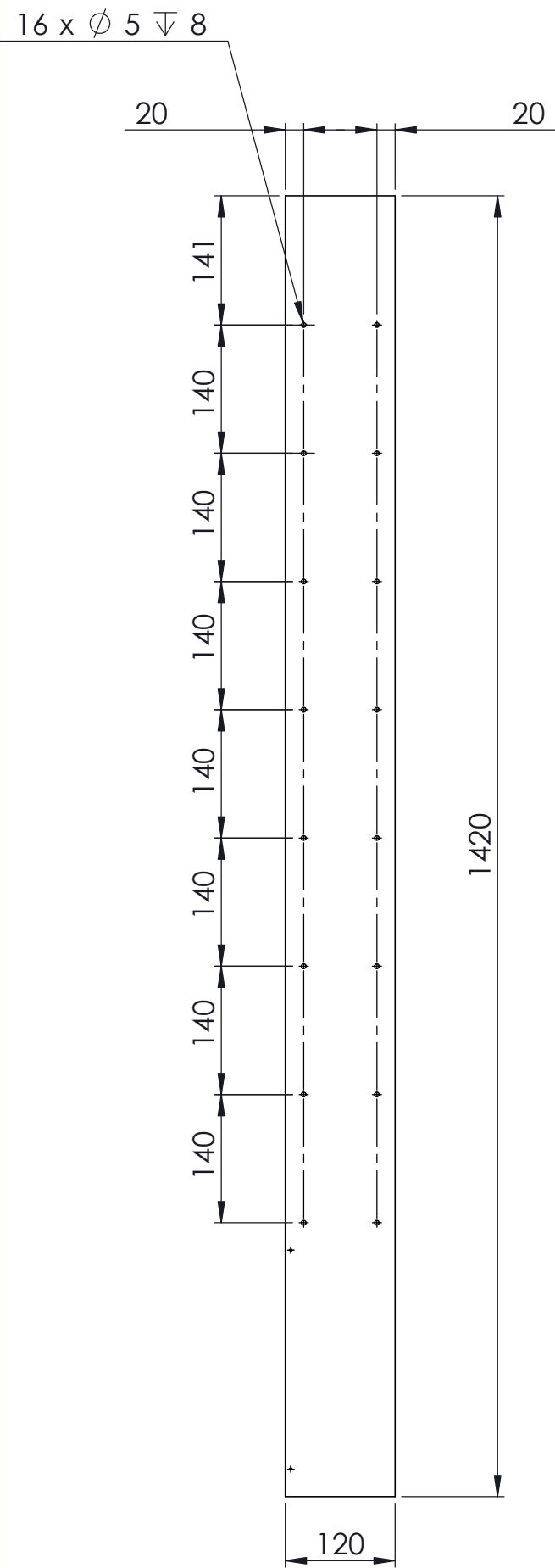

PROJET N°: 3

COLONNE 160 CD

DESCRIPTIF :
PLANCHE B

PUBLIE LE : 21/12/2008

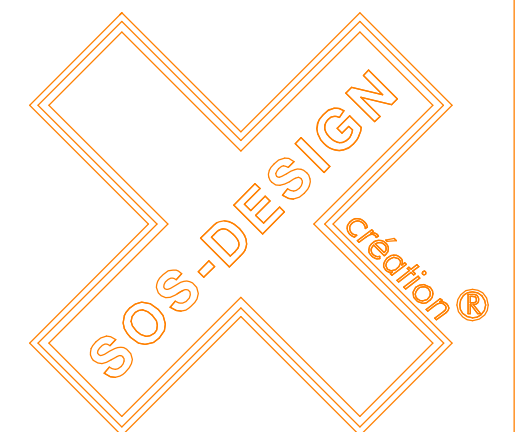

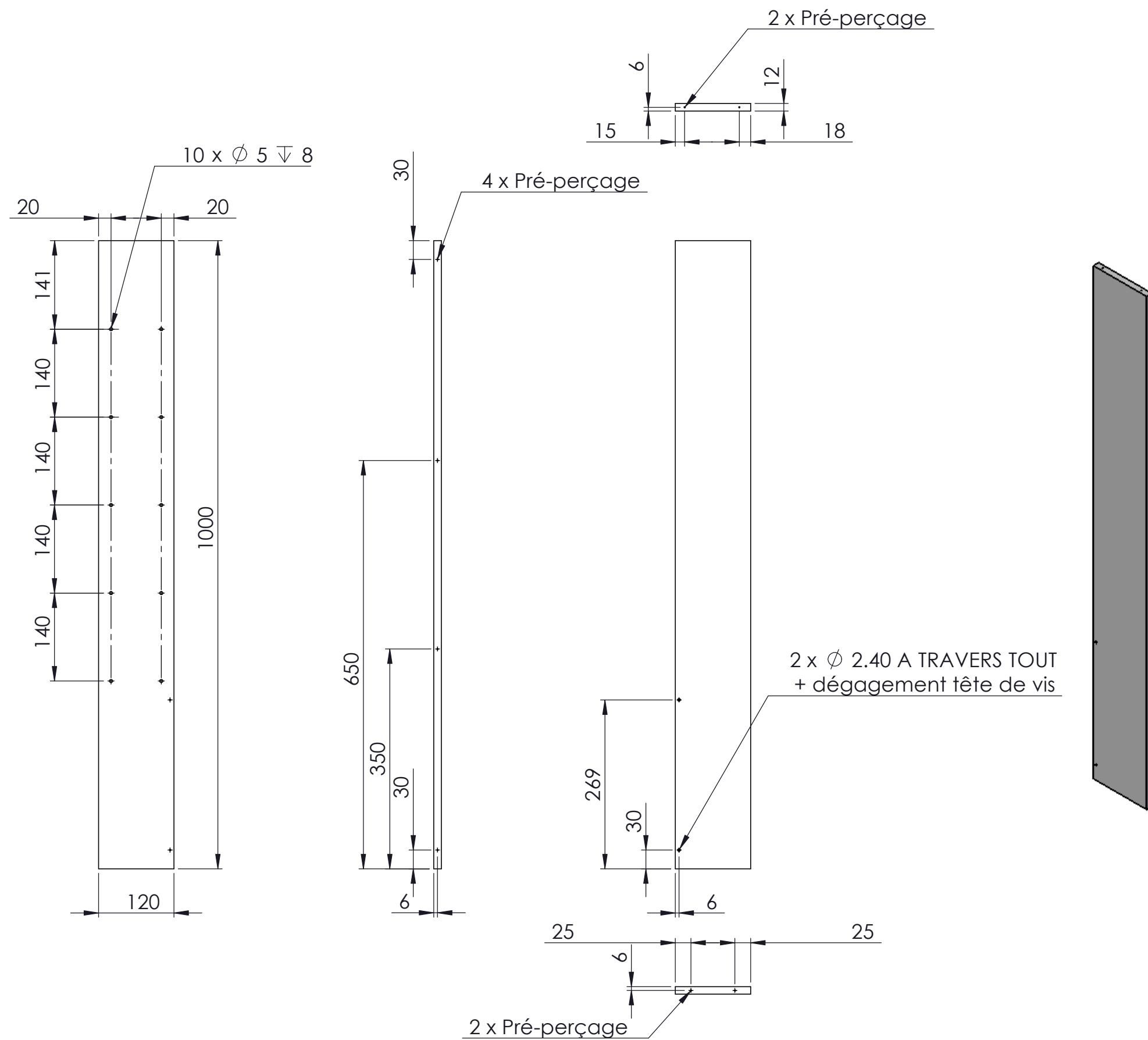

PROJET N°: 3

COLONNE 160 CD

DESCRIPTIF :
PLANCHE C

PUBLIE LE : 21/12/2008

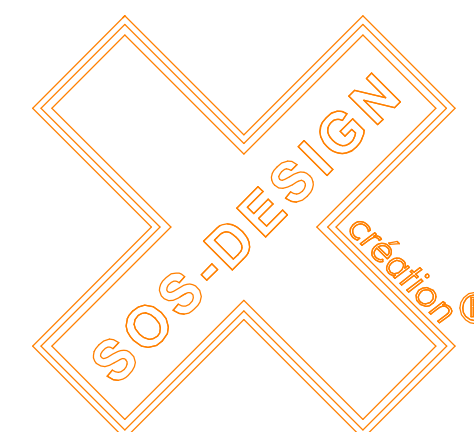

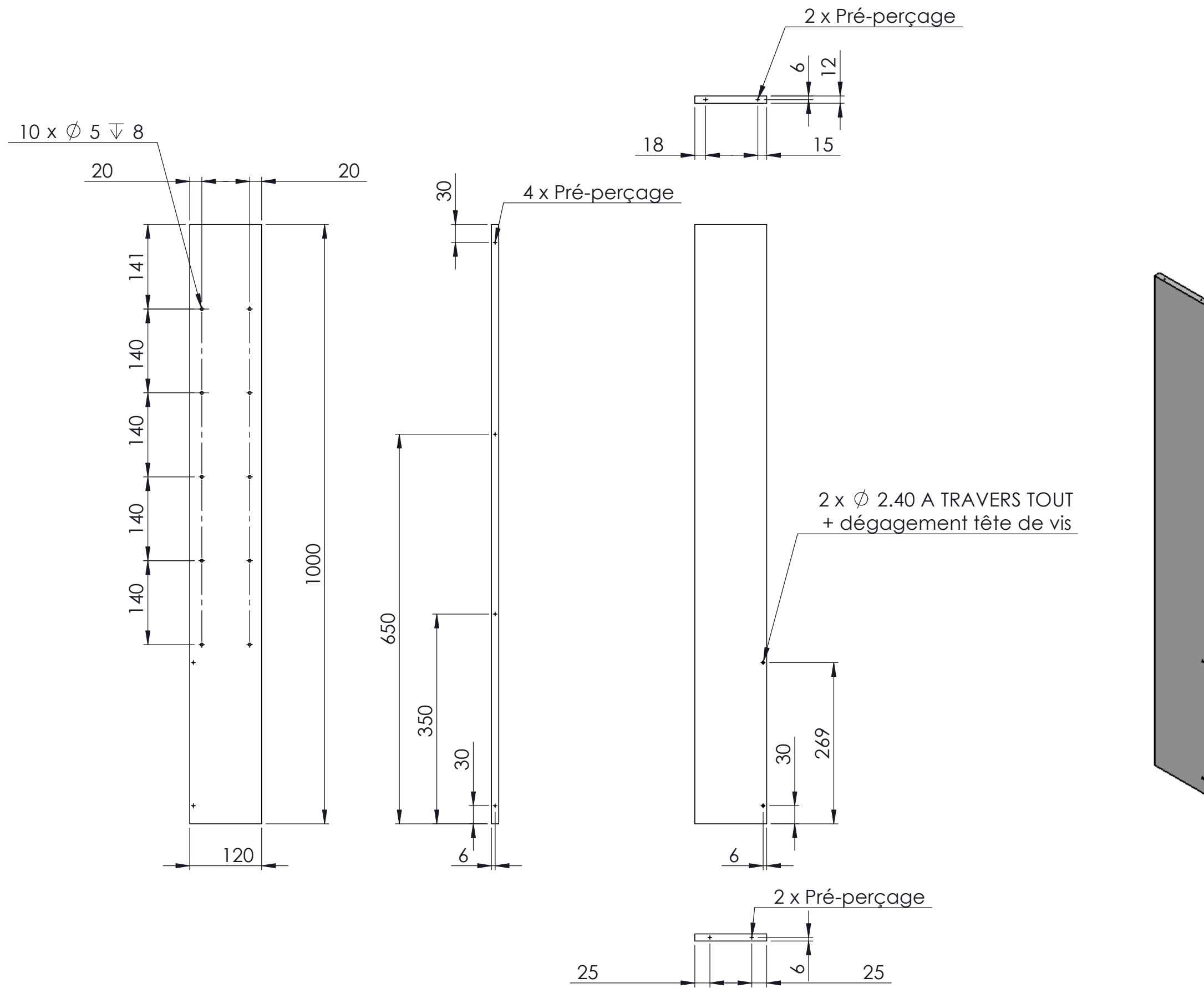

PROJET N°: 3

COLONNE 160 CD

DESCRIPTIF :
PLANCHE D

PUBLIE LE : 21/12/2008

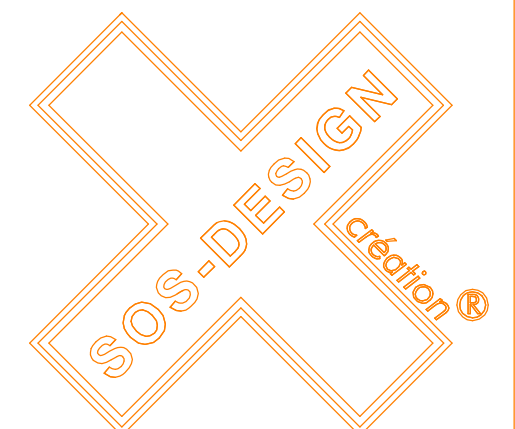

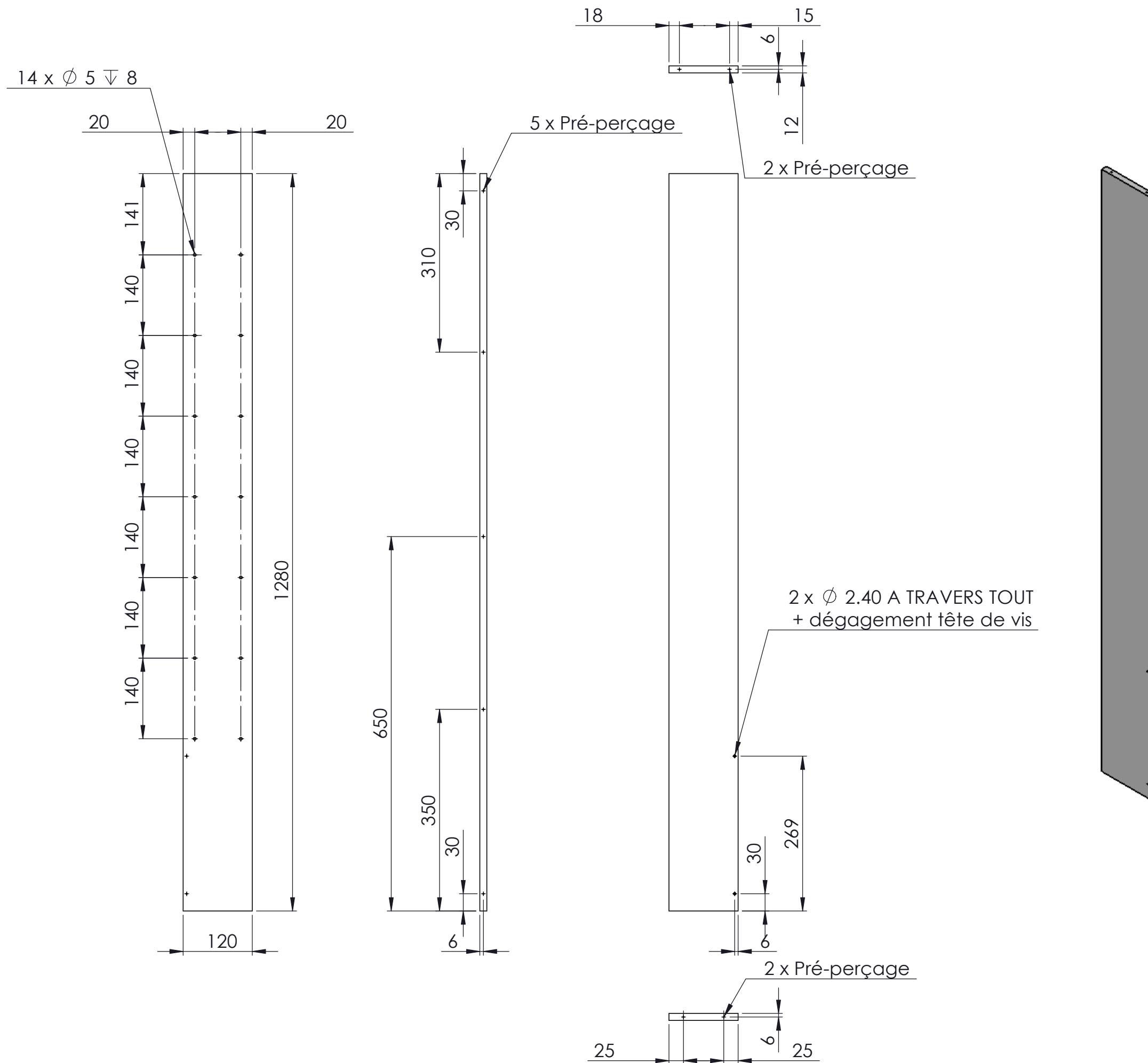

PROJET N°: 03

COLONNE 160 CD

DESCRIPTIF :
PLANCHE E

PUBLIE LE : 21/12/2008

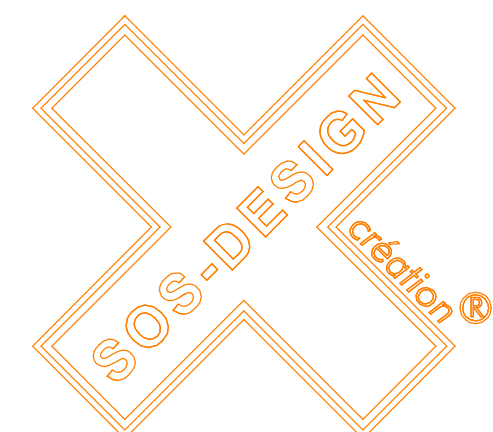

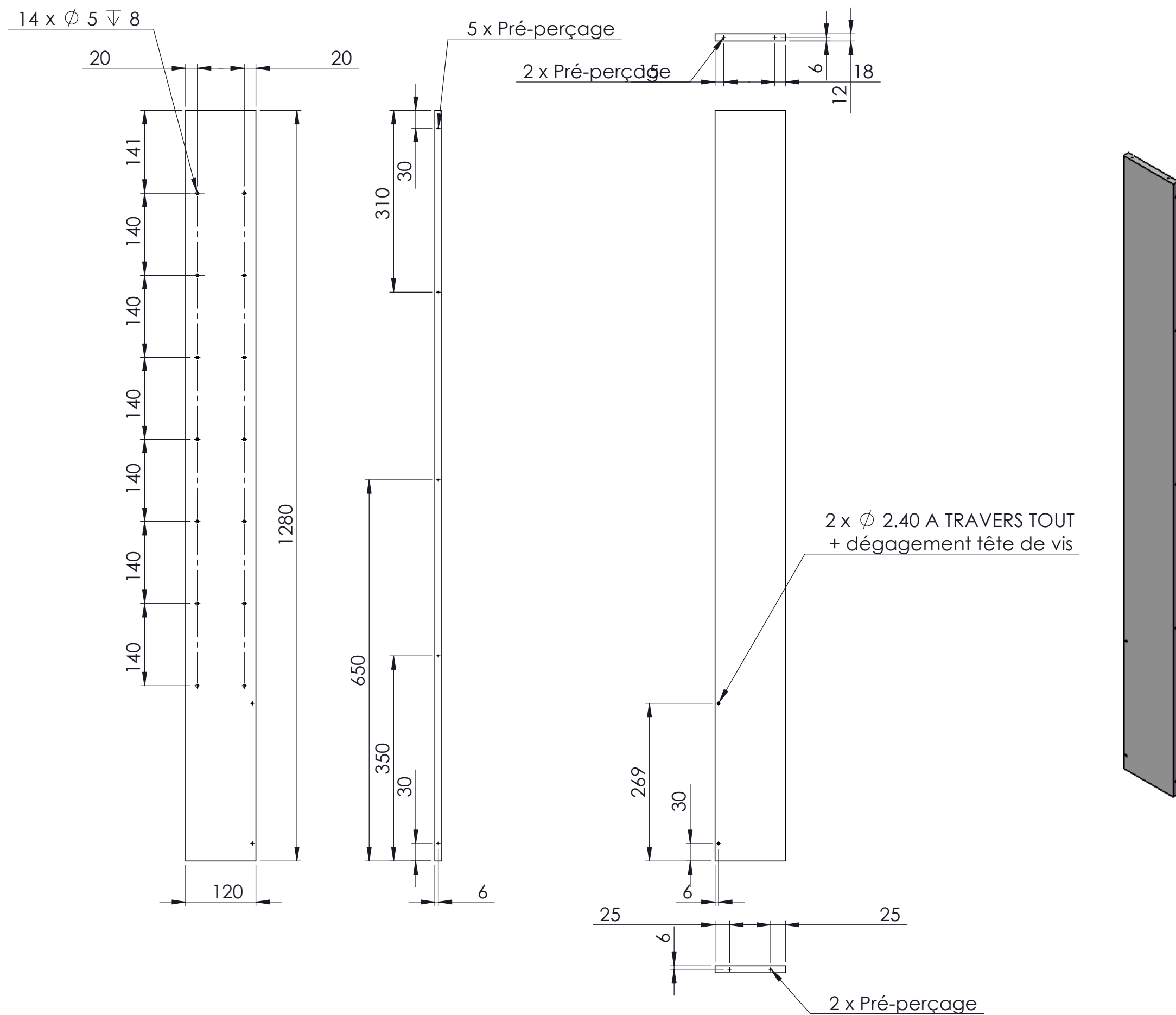

PROJET N°: 3

COLONNE 160 CD

DESCRIPTIF :
PLANCHE F

PUBLIE LE : 21/12/2008

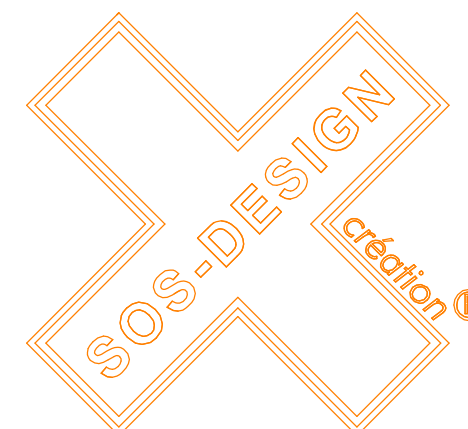

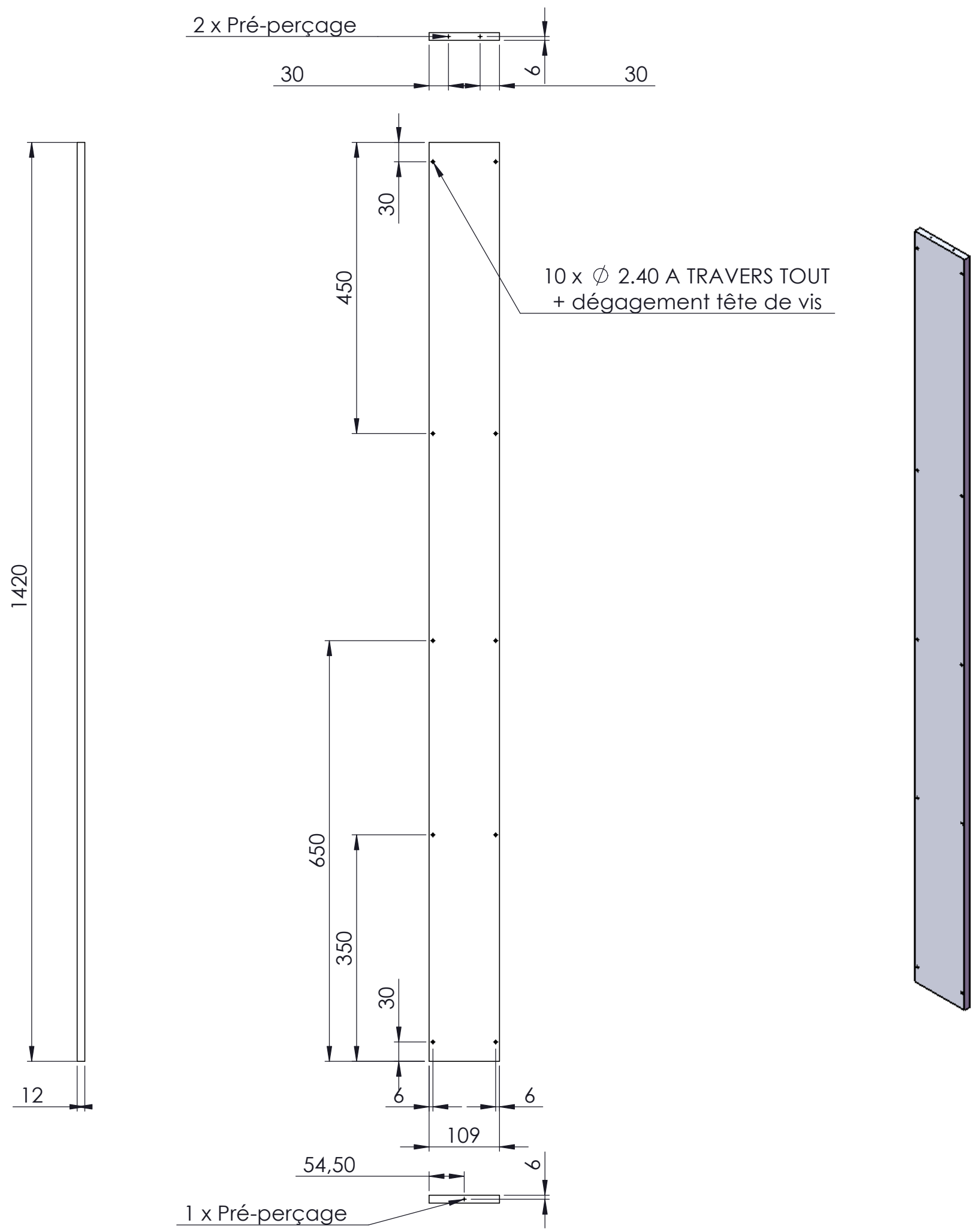

PROJET N°: 3

COLONNE 160 CD

DESCRIPTIF :
PLANCHE J

PUBLIE LE : 21/12/2008

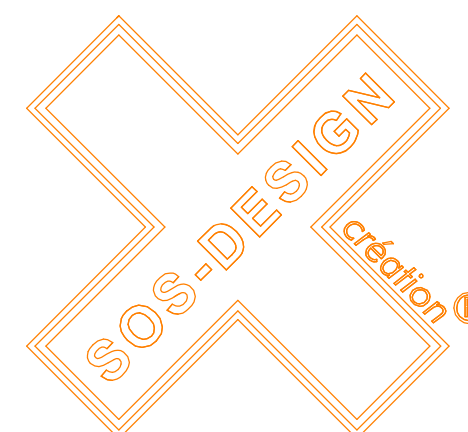

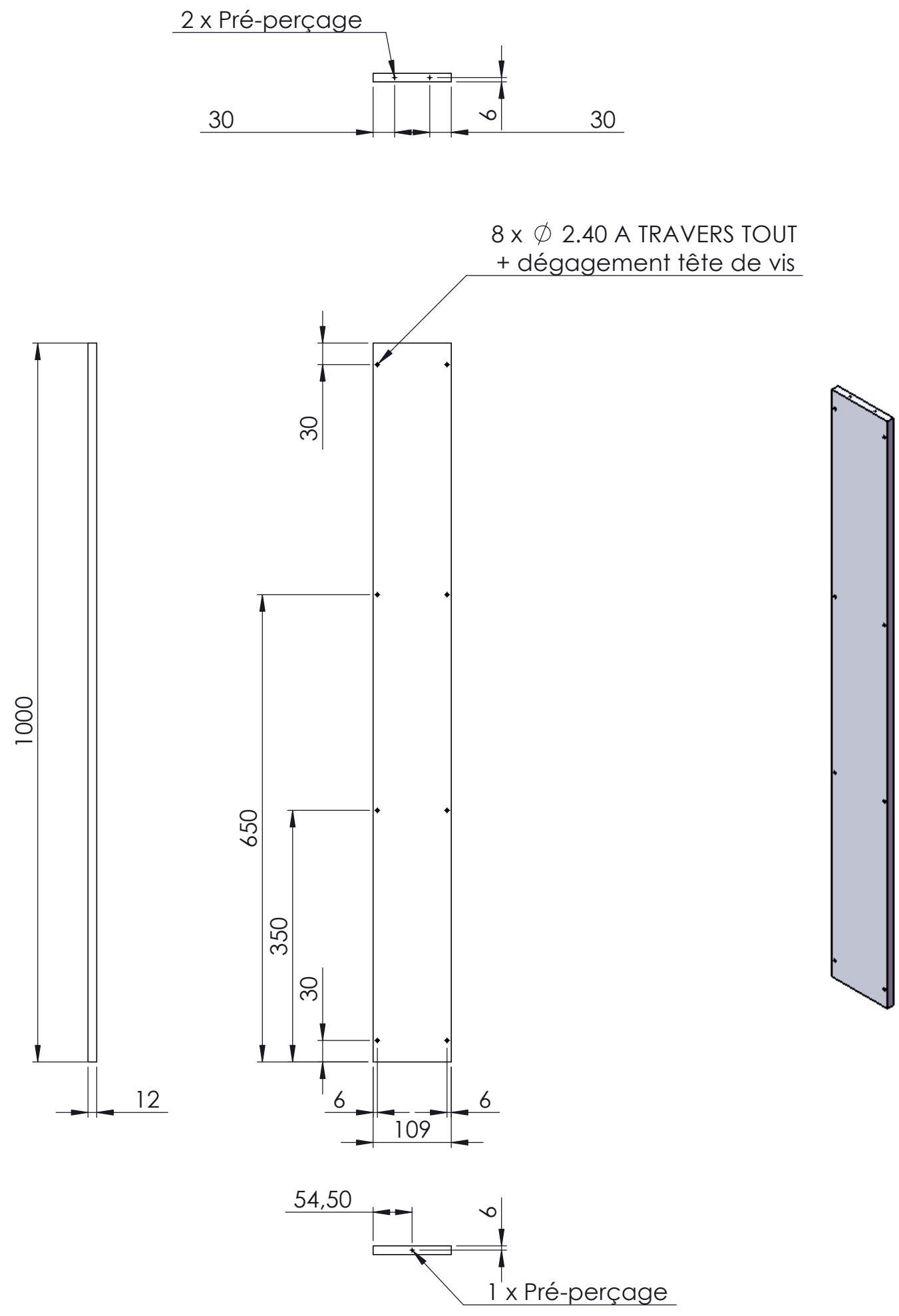

PROJET N°: 3

COLONNE 160 CD

DESCRIPTIF :

PLANCHE K

PUBLIE LE : 21/12/2008

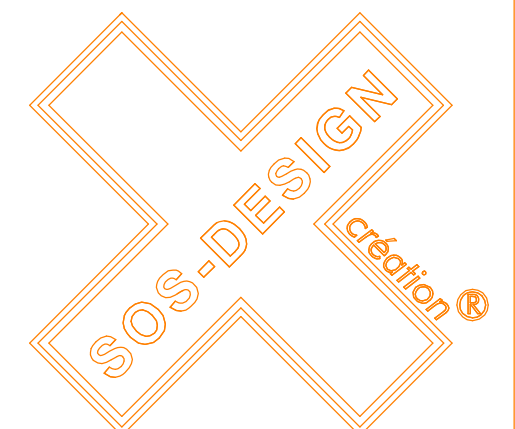

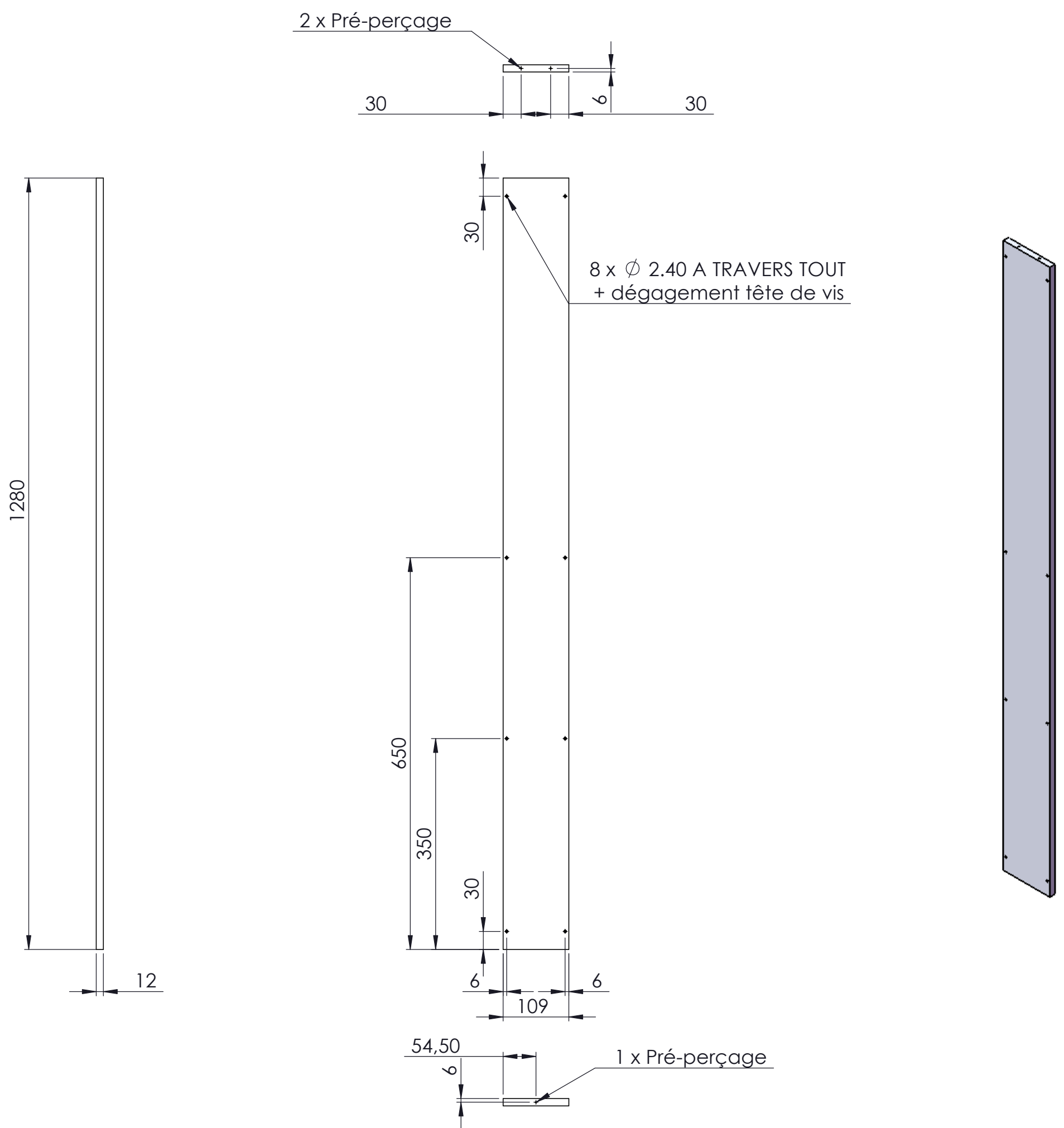

PROJET N°: 3

COLONNE 160 CD

DESCRIPTIF :
PLANCHE L

PUBLIE LE : 21/12/2008



PLANCHE H



PLANCHE G

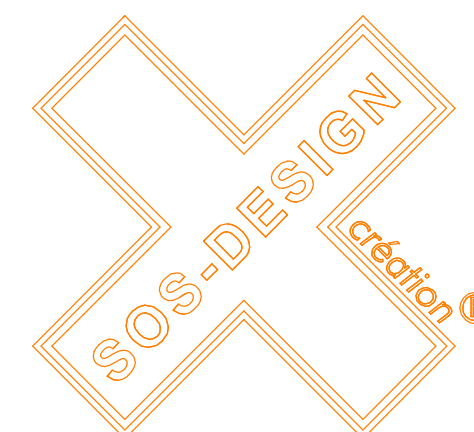

PLANCHE I

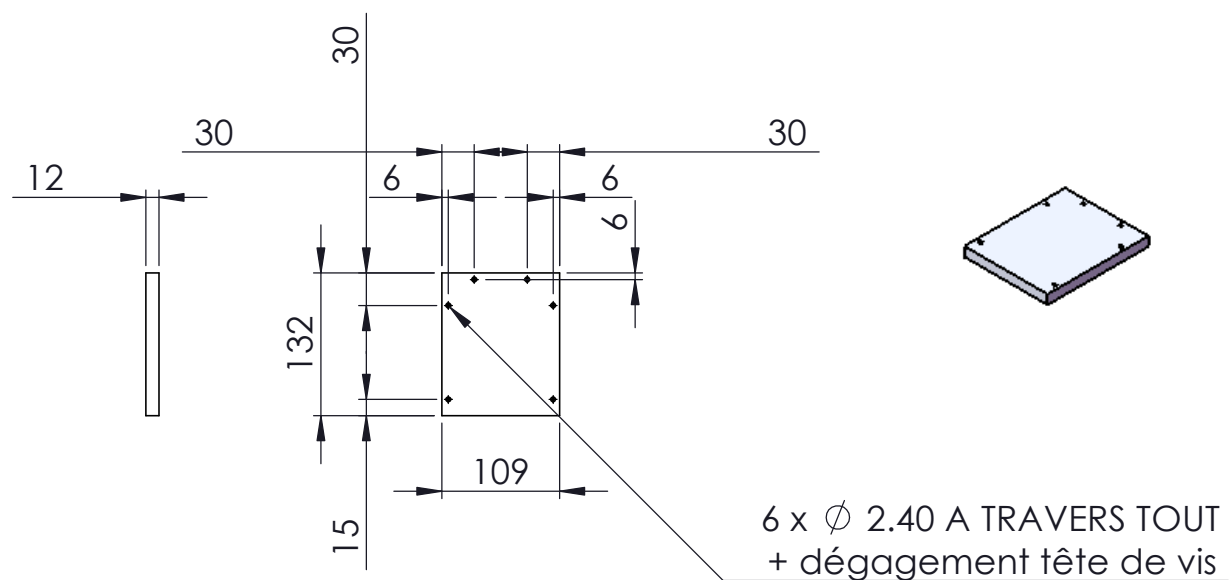

PROJET N°: 3

COLONNE 160 CD

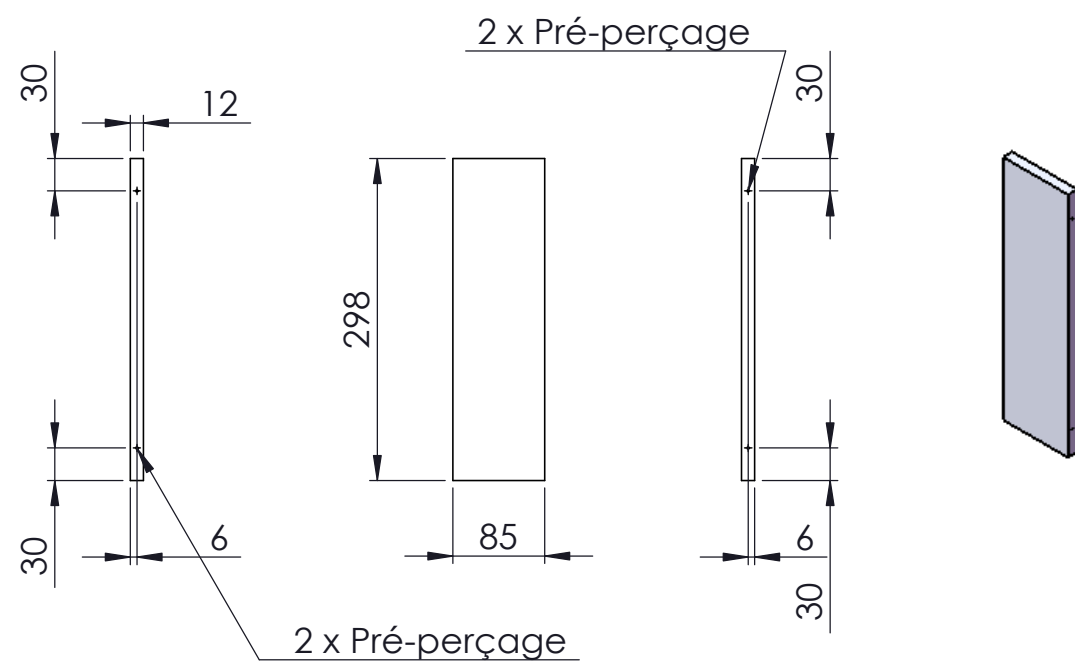
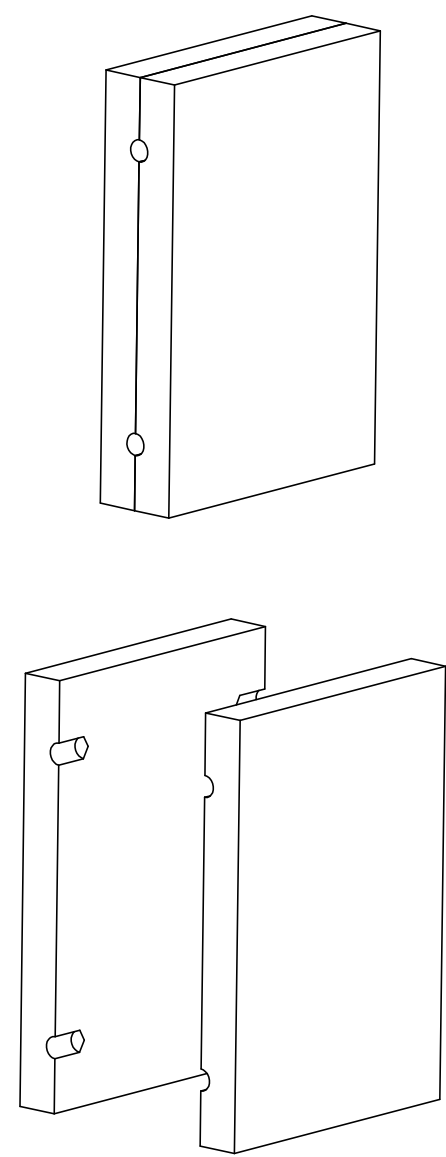
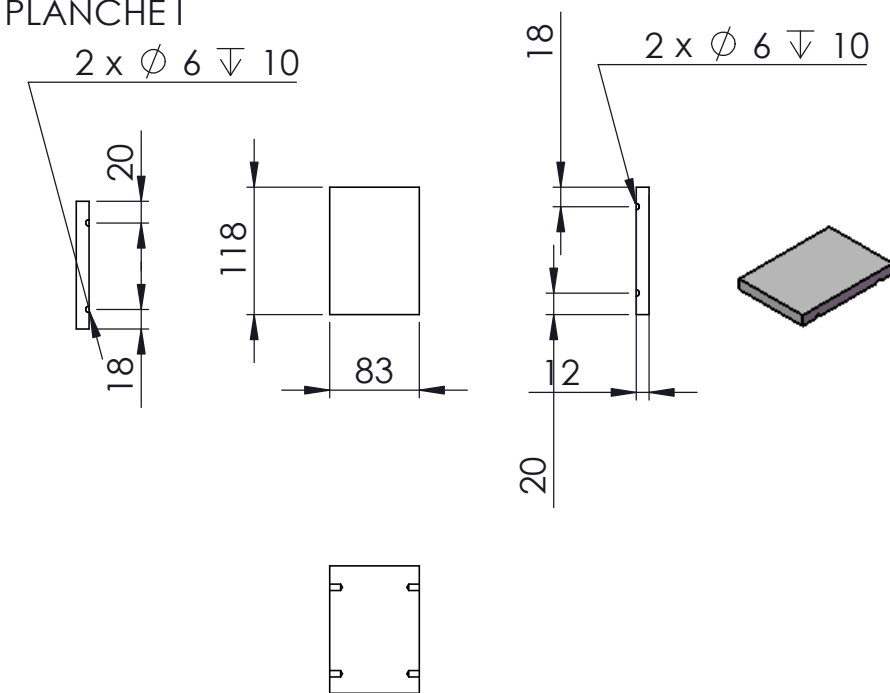
DESCRIPTIF :

PLANCHE G
PLANCHE H
PLANCHE I

Pour effectuer les perçages sur les planches I, les serrer 2 par 2 dans un étau puis percer.

PUBLIE LE : 21/12/2008

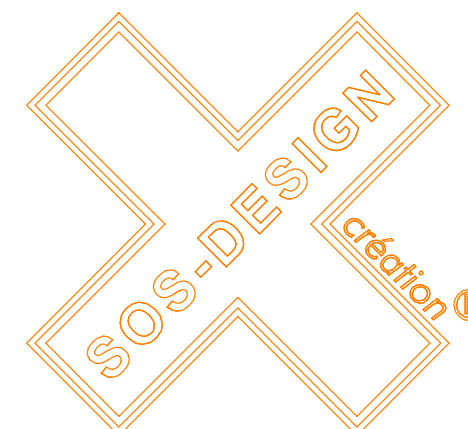

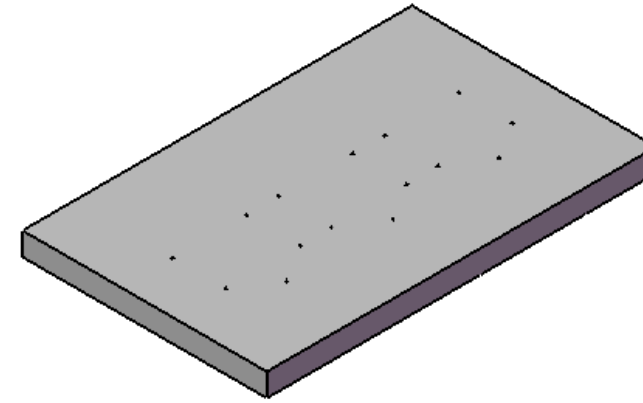
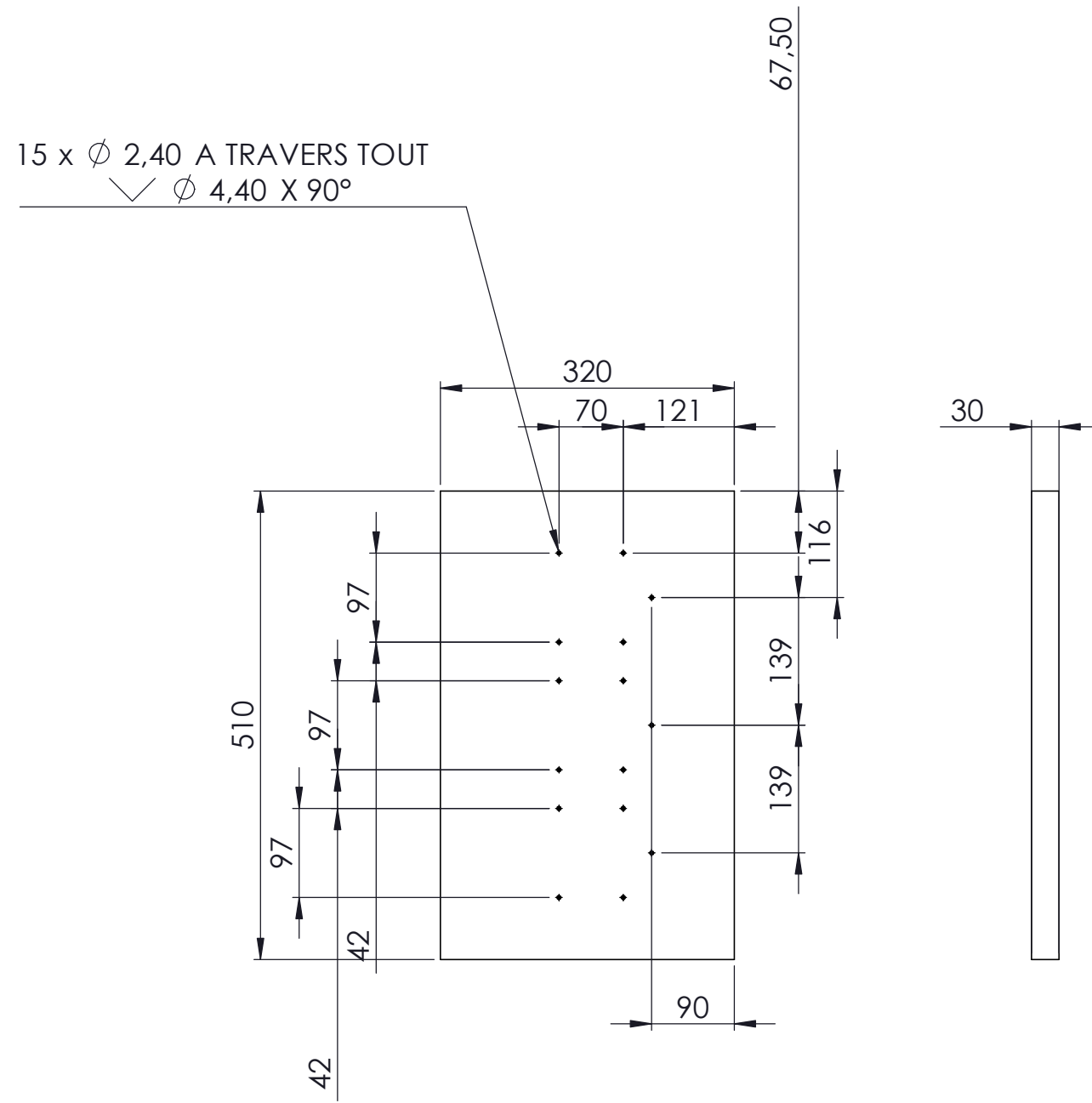

PROJET N°: 3

COLONNE 160 CD

DESCRIPTIF :

PLANCHE M

PUBLIE LE : 21/12/2008

